

6 Ground Floor
1 : 100

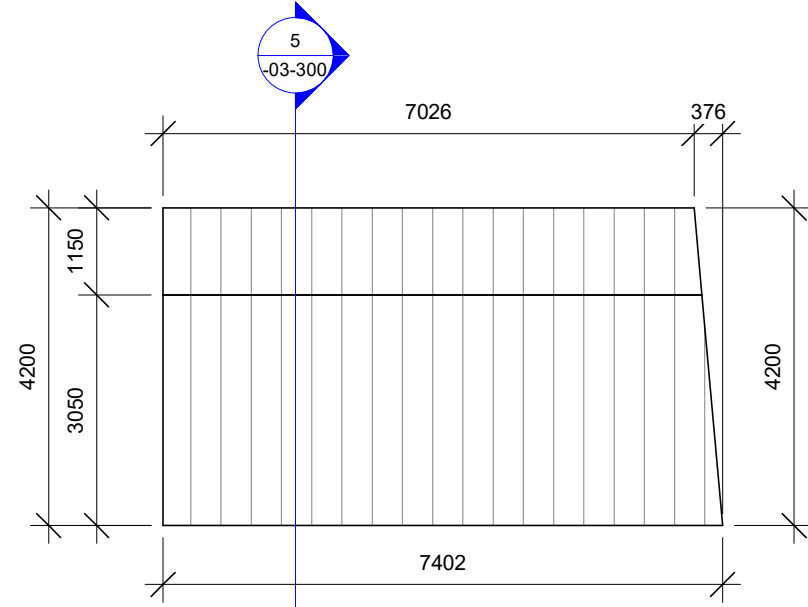

7 Roof
1 : 100

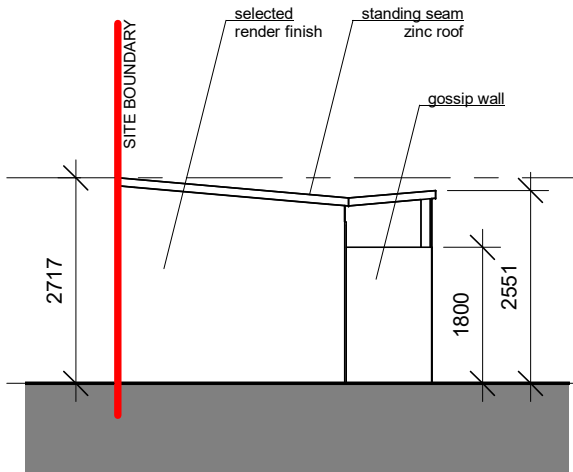

1 Side (East) Elevation
1 : 100

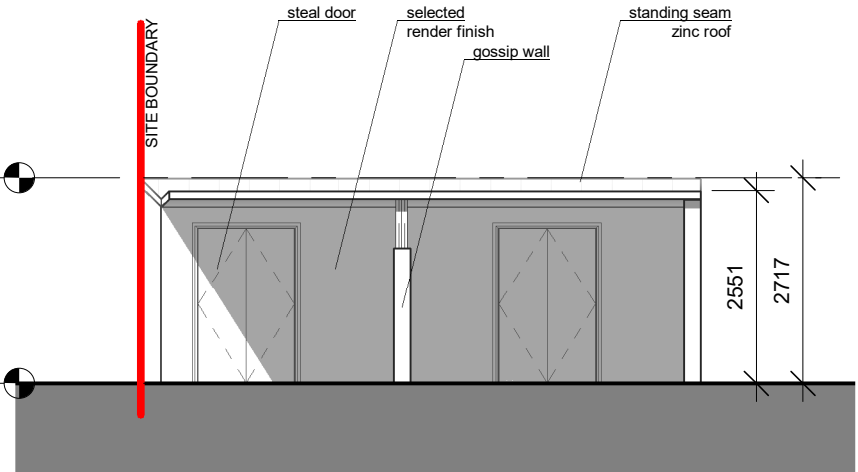

3 Front (North) Elevation
1 : 100

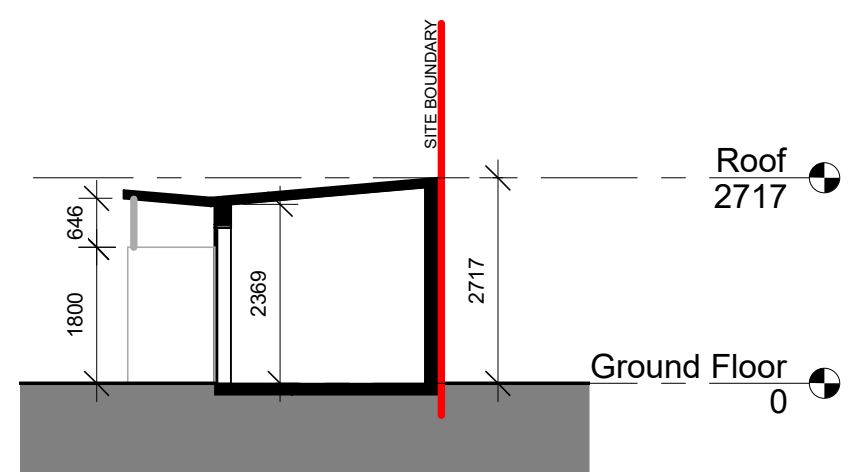

5 Section A-A
1 : 100

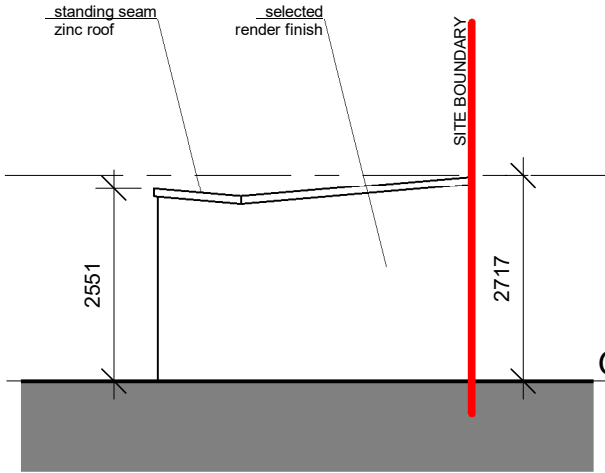

4 Side (West) Elevation
1 : 100

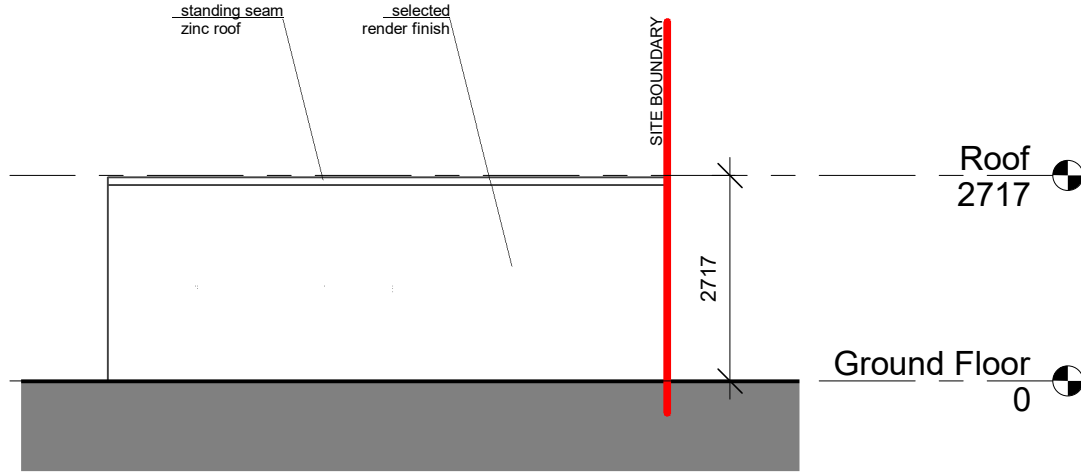

2 Rear (South) Elevation
1 : 100



Rev	Description	By	Date

	VINCENT HANNON ARCHITECTS Sligo 1-3 Abbey Street Abbeyquarter North Sligo, F91 X260 E: info@vha.ie www.vha.ie	Galway Suite 4, Cloch Mhile Dublin Road, Galway, H91 V97E T: 091 483 934	Maynooth Office 20, Block B, Maynooth Business Campus, Kildare T: 071 915 0022
	© THIS DRAWING IS PROTECTED BY COPYRIGHT AND IS TO BE READ IN CONJUNCTION WITH ALL RELEVANT SPECIFICATIONS AND DRAWINGS. DO NOT SCALE OFF THIS DRAWING. IT IS THE CONTRACTOR'S RESPONSIBILITY TO ENSURE COMPLIANCE WITH ALL ASPECTS OF THE CURRENT BUILDING REGULATIONS. IT IS THE CONTRACTOR'S RESPONSIBILITY TO ENSURE COMPLIANCE WITH ALL CONDITIONS IMPOSED BY THE LOCAL PLANNING AUTHORITY. IF IN DOUBT ASK.		
Client: Clúid Housing Project: Proposed Residential Development 102 Main Street, Portlaoise, Co. Laois		Drawing Description: Proposed Bin Store & Charging Room Plans, Section A-A & Elevations Scale: 1 : 100	
Status: Planning		Drawing No: 200301 -03-300 Rev:	
Date: April 2024		Drawn by: PS Checked by: BF	